

This drawing is the property of Rev-A-Shelf (RAS) and is disclosed in confidence to the extent its subject matter is original to RAS. Any vendor receiving this drawing from RAS shall hold and use this drawing for the sole benefit of RAS and shall not disclose it to, or use or reproduce it for any third party, or perform any act adverse to the interest of RAS with respect to this drawing without the express written permission of RAS. Vendors shall not revise any physical, dimensional or performance characteristic unless authorized by Rev-A-Shelf Engineering.

REV.	DATE	BY	DESCRIPTION OF CHANGE

INCH [MM]	AMERICAN PROJECTION	DRAWN	BY	DATE	REV-A-SHELF, INC.
			PFC	6/25/19	
TOLERANCES			MATERIAL	DRAWING NO.	SCALE
MAT. DEC. (WOOD) .XX ±.03 [.8mm] (OTHER) .XX ±.02 [.5mm] (ALL) .XXX ±.005 [.13 mm] FRACTIONS ±1/32 [.8 mm]			FINISH	448-BDDSC-5C	0.187
ANGLES ±1/2°			PART NO.		SHEET OF
			448-BDDSC-5C		1 2

CUSTOMER DRAWING

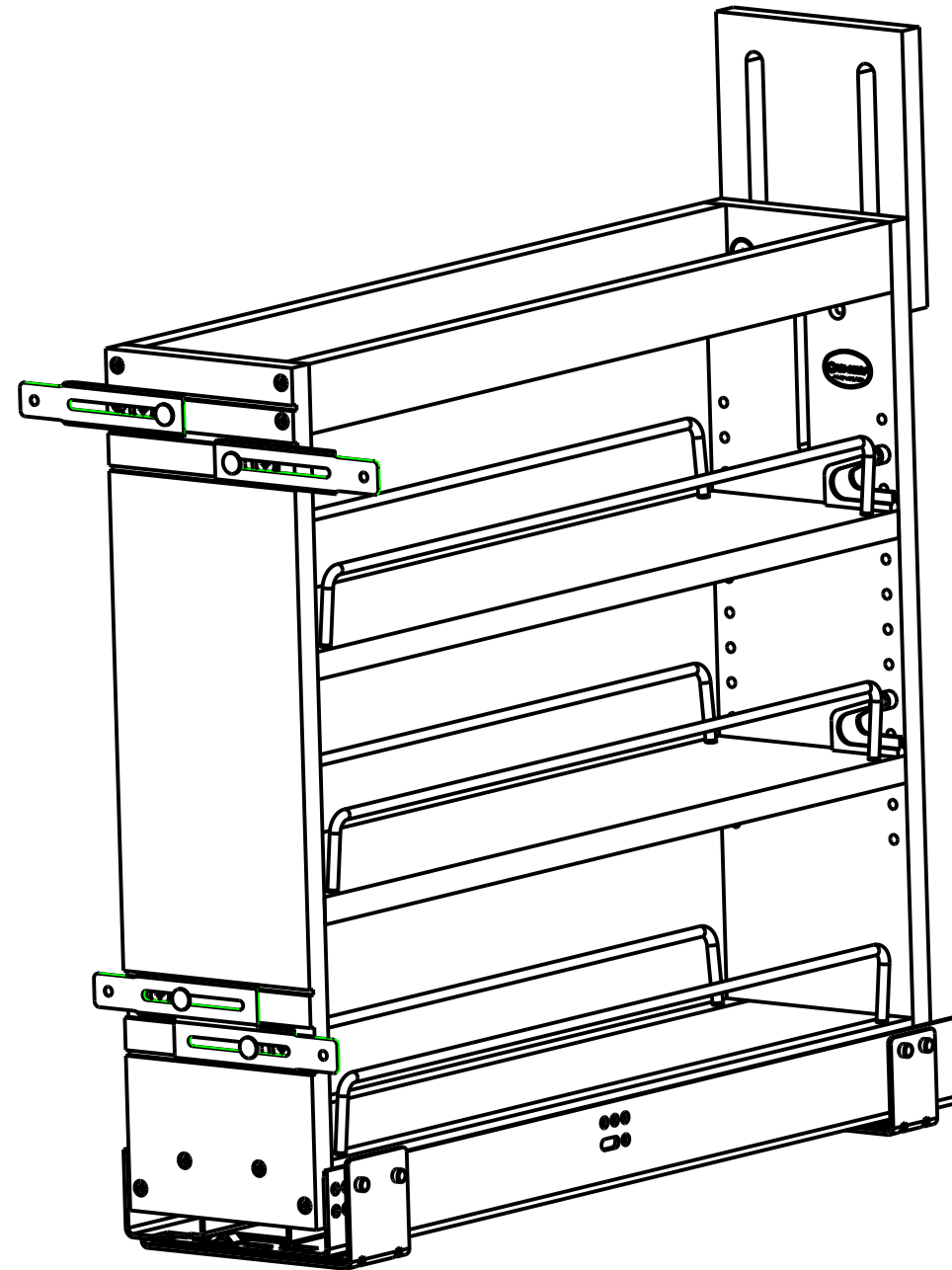

PART DIMENSIONS	
WIDTH	5.94 [105.9]
DEPTH	21.65 [550.0]
HEIGHT	25.50 [647.8]

MIN CABINET OPENING				
	FACE FRAME	FRAMELESS	INSET FACE FRAME	INSET FRAMELESS
WIDTH	6.00 [152.4]	6.00 [152.4]	6.00 [152.4]	6.00 [152.4]
DEPTH	21.65 [550.0]	21.65 [550.0]	22.40 [569.0]	22.40 [569.0]
HEIGHT	25.50 [647.7]	25.50 [647.7]	25.50 [647.7]	25.50 [647.7]

SLIDE SPECIFICATIONS				
SLIDE MANUFACTURER	BLUM			
SLIDE PART NUMBER	569H5330B	RELEASE PART NUMBER		
SLIDE TYPE	UNDERMOUNT	SLIDE EXTENSION	FULL	MAX WEIGHT RATING
SLIDE CLOSING	SELF/SOFT	SLIDE LENGTH	21.65 [550.0]	
SLIDE MOUNTING	UNDERMOUNT	SLIDE FINISH	ZINC	110LB

CUSTOMER DRAWING

This drawing is the property of Rev-A-Shelf (RAS) and is disclosed in confidence to the extent its subject matter is original to RAS. Any vendor receiving this drawing from RAS shall hold and use this drawing for the sole benefit of RAS and shall not disclose it to, or use or reproduce it for any third party, or perform any act adverse to the interest of RAS with respect to this drawing without the express written permission of RAS. Vendors shall not revise any physical, dimensional or performance characteristic unless authorized by Rev-A-Shelf Engineering.

REV.	DATE	BY	DESCRIPTION OF CHANGE

INCH [MM]	AMERICAN PROJECTION	DRAWN	BY	DATE	
			PFC	6/25/19	
TOLERANCES		MATERIAL		DRAWING NO.	SCALE
MAT.	DEC.	FINISH		448-BDDSC-5C	0.083
(WOOD) .XX ±.03 [8mm]	(OTHER) .XX ±.02 [5mm]			PART NO.	SHEET OF
(ALL) .XXX ±.005 [13 mm]	FRACTIONS ±1/32 [8 mm]			448-BDDSC-5C	2 OF 2