

- NOTES:
 1. PRODUCT DESIGNED FOR 1.5" FACE FRAME CABINET.
 2. UPPER TRAY EQUIPED WITH 400MM BALL BEARING FULL EXTENSION SLIDES.

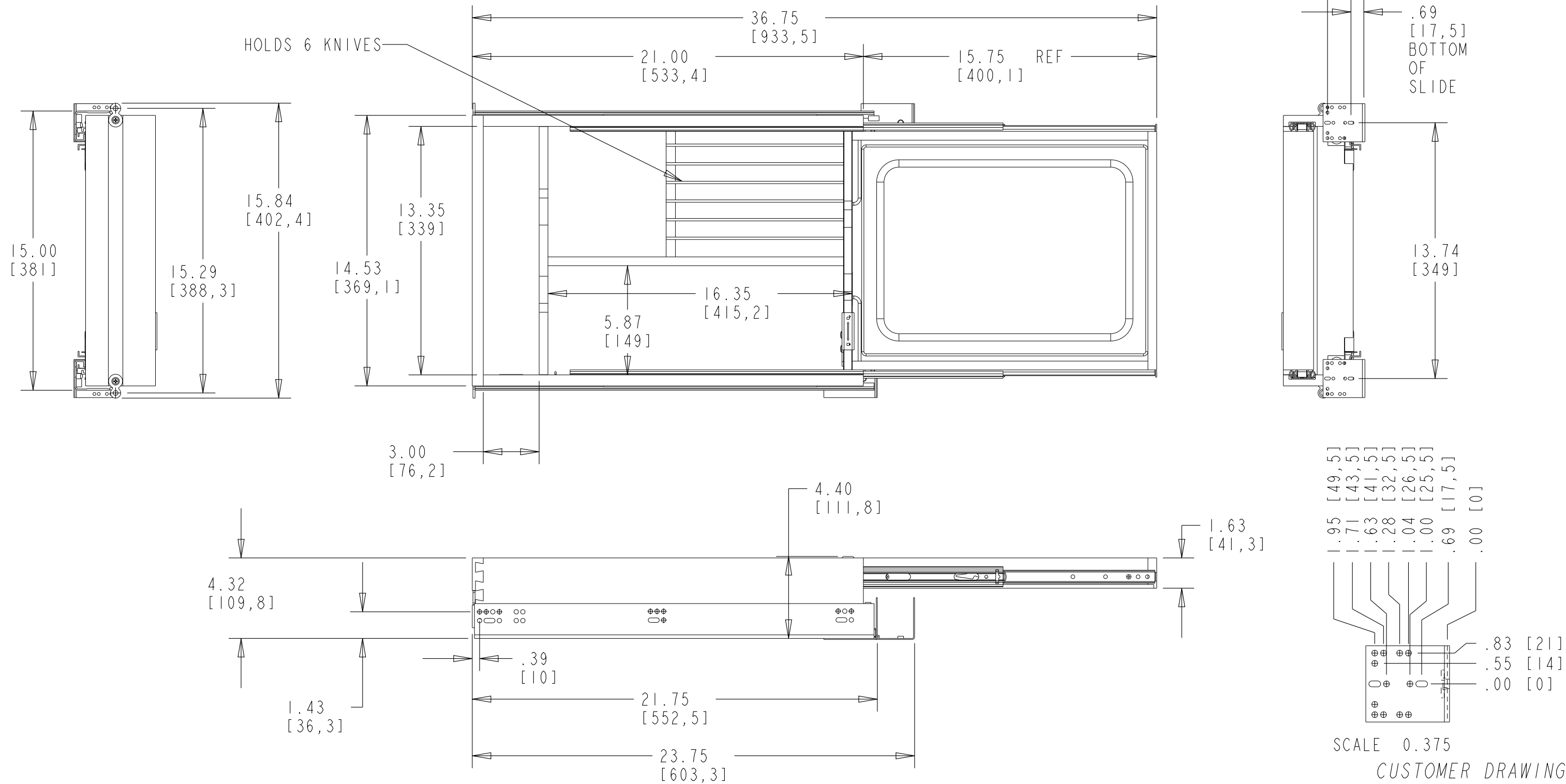

SCALE 0.375
 CUSTOMER DRAWING

This drawing is the property of Rev-A-Shelf (RAS) and is disclosed in confidence to the extent its subject matter is original to RAS. Any vendor receiving this drawing from RAS shall hold and use this drawing for the sole benefit of RAS and shall not disclose it to, or use or reproduce it for any third party, or perform any act adverse to the interest of RAS with respect to this drawing without the express written permission of RAS. Vendors shall not revise any physical, dimensional or performance characteristic unless authorized by Rev-A-Shelf Engineering.

REV.	DATE	BY	DESCRIPTION OF CHANGE

INCH [MM]	AMERICAN PROJECTION	BY	DATE	REV-A-SHELF, INC.
		DRAWN	KRR 6-29-20	
TOLERANCES		MATERIAL	DRAWING NO.	SCALE
MAT. DEC. (WOOD) .XX ±.03 [.8mm] (OTHER) .XX ±.02 [.5mm] (ALL) .XXX ±.005 [.13 mm] FRACTIONS ±1/32 [.8 mm]		FINISH	4KCB-18HSC-1	0.188
ANGLES ±1/2°		PART NO.		SHEET OF
		4KCB-18HSC-1		1 2

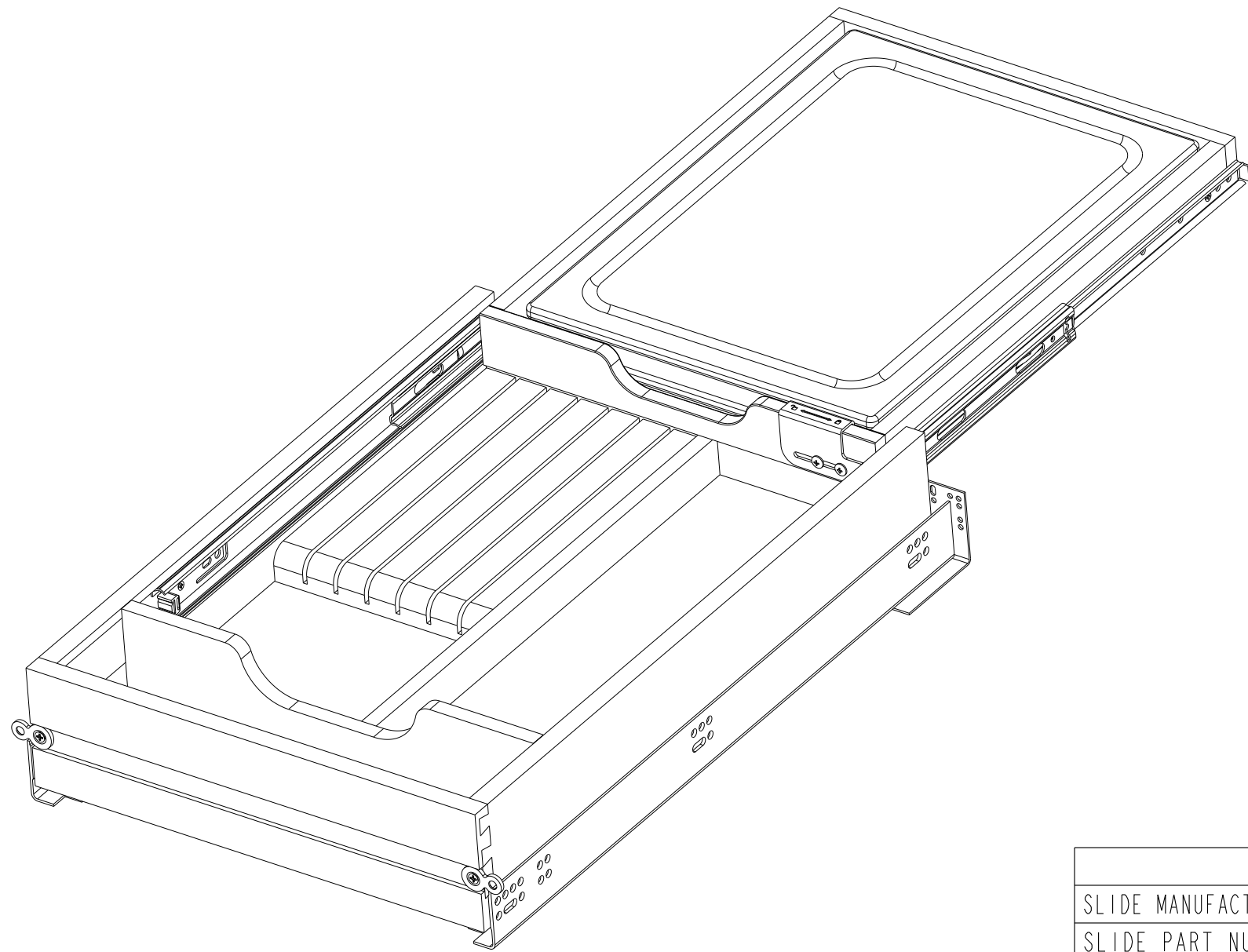

PART DIMENSIONS		
	MIN	MAX
WIDTH	15.00	
DEPTH	21.75	23.75
HEIGHT	4.40	
CONTAINER CAPACITY		
CONTAINER UOM		

MIN CABINET OPENING				
	FACE FRAME	FRAMELESS	INSET FACE FRAME	INSET FRAMELESS
WIDTH	15.00	15.00	15.00	15.00
DEPTH	21.75	21.75	22.50	22.50
HEIGHT	4.50	4.50	4.50	4.50

SLIDE SPECIFICATIONS				
SLIDE MANUFACTURER	BLUM			
SLIDE PART NUMBER	563H5330B	RELEASE PART NUMBER	T51-1801	
SLIDE TYPE	TANDUM PLUS BLUMOTION	SLIDE EXTENSION	FULL	MAX WEIGHT RATING
SLIDE CLOSING	SOFT	SLIDE LENGTH	21.00 [533MM]	
SLIDE MOUNTING	SIDE	SLIDE FINISH	ZINC	100 LB

CUSTOMER DRAWING

This drawing is the property of Rev-A-Shelf (RAS) and is disclosed in confidence to the extent its subject matter is original to RAS. Any vendor receiving this drawing from RAS shall hold and use this drawing for the sole benefit of RAS and shall not disclose it to, or use or reproduce it for any third party, or perform any act adverse to the interest of RAS with respect to this drawing without the express written permission of RAS. Vendors shall not revise any physical, dimensional or performance characteristic unless authorized by Rev-A-Shelf Engineering.

REV.	DATE	BY	DESCRIPTION OF CHANGE

INCH [MM]	AMERICAN PROJECTION 	DRAWN	BY	DATE	REV-A-SHELF, INC.
		KRR		6.29-20	
TOLERANCES		ANGLES ±1/2°	MATERIAL	DRAWING NO.	SCALE
MAT. (WOOD) .XX ±.03 [.8mm]	DEC. (OTHER) .XX ±.02 [.5mm]		FINISH	4KCB-18HSC-1	0.250
(ALL) .XXX ±.005 [.13 mm]				PART NO.	SHEET OF
FRACTIONS ±1/32 [.8 mm]				4KCB-18HSC-1	2 OF 2